

International 420 Class

420 Class National Sailing Championships 2009.

SAILING INSTRUCTIONS

1 RULES

1.1 The regatta will be governed by the rules as defined in **The Racing Rules of Sailing (RRS) 2009 - 2012.**

1.2 The following prescriptions of the South African National Authority will apply:

The South African Sailing Requirements for National Championships

1.3 **The Equipment Rules of Sailing (ERS) 2005-8 and all Class Rules** will apply.

2 NOTICES TO COMPETITORS

Notices to competitors will be posted on the official notice board(s) located at ZVYC

3 CHANGES TO SAILING INSTRUCTIONS

Any change to the sailing instructions will be posted before 09:00 on the day it will take effect, except that any change to the schedule of races will be posted by 19:00 on the day before it will take effect.

4 SIGNALS MADE ASHORE

4.1 Signals made ashore will be displayed on the ZVYC flagstaff

4.2 When flag AP is displayed ashore, '1 minute' is replaced with 'not less than 30 minutes' in the race signal AP.

4.3 Yachts shall comply with their class buoyancy and safety requirements.

All competitors shall wear a personal buoyancy aid capable of supporting a 5Kg. steel weight at all times while afloat in a yacht.

Youth category competitors shall wear a personal buoyancy aid at all times while afloat in a yacht.

Wet or Dry suits do not constitute adequate buoyancy!

5 SCHEDULE OF RACES

5.1 Dates of racing:

25 April 2009 racing
26 April 2009 racing
27 April 2009 racing

- 5.3** The scheduled time of the Warning Signal for the first race on 25 April 2009 is 13.55 and for each following day is 9.55.
- 5.4** When there has been a long postponement and when more than one race (or sequence or races,]) will be held on the same day, the Warning Signal for the first race and each succeeding race will be made as soon as practicable. To alert boats that a race or sequence of races will begin soon, Flag "L" will be displayed before a Warning Signal is displayed.
- 5.5** On the last day of the regatta no Warning Signal will be made after 16.00.

6 RACING AREAS

- 6.1** Zeekoe Vlei

7 THE COURSES

- 7.1** The diagrams in Attachment 1 show the courses, including the approximate angles between legs, the order in which marks are to be passed, and the side on which each mark is to be left.

8 MARKS

- 8.1** Marks 1, 2, 3 and 4 will be inflatable yellow marks.
- 8.2** The starting and finishing marks will be small red marks.
- 8.3** A Race Committee boat signalling a change of a leg of the course is a mark as provided in instruction 15.2.

9 THE START

- 9.1** Races will be started by using RRS 26 with the Warning Signal given 5 minutes before the starting signal.
- 9.2** The starting line will be between the mast on the ZVYC Committee boat and a small red mark.
- 9.3** A boat starting later than 4 minutes after her starting signal will be scored Did Not Start. This changes RRS A4 and A5.
- 9.4** If a boat breaks RRS 30.3, the Race Committee at Mark 1 will point flag X at her, make a sound signal and hail her sail number. The hailed boat shall immediately leave the course area. If she fails to do so she will be disqualified without a hearing and her score will not be excluded. This changes RRS A5.

10 CHANGE OF THE NEXT LEG OF THE COURSE

- 10.1** To change the next leg of the course, the Race Committee will move the original mark (or the finishing line) to a new position.

11 THE FINISH

The finishing line will be between the mast of the ZVYC Committee boat and a small red mark

12 PENALTY SYSTEM

- 12.1** For the 420 class RRS 44.1 and 44.2 are changed so that only one 360° turn, including one tack and one gybe, is required.
- 12.2** A boat that has taken a penalty or retired under RRS 31.2 or 44.1 shall complete an acknowledgment form at the Race Office within the protest time limit.
- 12.3** As provided in RRS 67, the protest committee may, without a hearing, penalize a boat that has broken RRS 42.

13 TIME LIMITS

Boats failing to finish within 20 minutes after the first boat sails the course and finishes will be scored Did Not Finish. This changes RRS 35, A4 and A5.

14 NATIONAL CHAMPIONSHIP REQUIREMENTS

In order to qualify as a National Class Championship the following criteria shall be satisfied:

- * A minimum of ten valid entries have been received no later than the closing time for entries one hour before the scheduled starting time of the first race;
- * At least ten finishers in any two races of the series;
- * At least four races completed.

15 PROTESTS AND REQUESTS FOR REDRESS

- 15.1** Protest forms are available at the Race Office. Protests shall be delivered there within the protest time limit.
- 15.2** The protest time limit is 60 minutes after the last boat has finished the last race of the day. The same time limit applies to protests by the race committee and Protest committee about incidents they observe in the racing area and to requests for redress. This changes RRS 61.3 and 62.2.
- 15.3** Notices will be posted within 30 minutes of the protest time limit to inform competitors of hearings and times thereof in which they are parties or named as witnesses. Hearings will be held in the jury room, located at ZVYC.
- 15.4** Notices of protests by the Race Committee or Protest Committee will be posted to inform boats under RRS 61.1(b).
- 18.5** A list of boats that, under instruction 17.4, have acknowledged breaking RRS 42 or have been disqualified by the protest committee will be posted before the protest time limit.
- 15.6** On the last day of the regatta a request for reopening a hearing shall be delivered
- (a) within the protest time limit if the requesting party was informed of the decision on the previous day;
 - (b) no later than 30 minutes after the requesting party was informed of the decision on that day.

This changes RRS 66.

- 15.7** On the last day of the regatta a request for redress from a Protest Committee decision shall be delivered no later than 30 minutes after the decision was posted. This changes RRS 62.2.

16 SCORING

- 16.1** The Low Point scoring system of Appendix A will apply.

- 16.2** 4 races are required to be completed to constitute a series.

- 16.3** (a) When fewer than 5 races have been completed, a boat's series score will be the total of her race scores.
(b) When from 5 to 9 races have been completed, a boat's series score will be the total of her race scores excluding her worst score.
(c) When 10 or more races have been completed, a boat's series score will be the total of her race scores excluding her two worst scores.

17 SAFETY REGULATIONS

- 17.1** All competitors shall wear a personal buoyancy aid capable of supporting a 5Kg. steel weight at all times while afloat in a yacht.

- 17.2** Wet or Dry suits do not constitute adequate buoyancy!

18 REPLACEMENT OF CREW OR EQUIPMENT

- 18.1** Substitution of competitors will not be allowed without prior written approval of the Race Committee

- 18.2** Substitution of damaged or lost equipment will not be allowed unless approved by the Race Committee. Requests for substitution shall be made in writing to the Committee at the first reasonable opportunity.

19 EQUIPMENT AND MEASUREMENT CHECKS

A boat or equipment may be inspected at any time for compliance with the Class Rules and Sailing Instructions. On the water, a boat can be instructed by a Race Committee Measurer to proceed immediately after the completion of a race to a designated area for inspection.

20 SUPPORT BOATS

- 20.1** Team leaders, coaches and other support personnel shall stay 150 metres outside areas where boats are racing from the time of the Preparatory Signal for the first class to start until all boats have finished or the Race Committee signals a postponement, general recall or abandonment. Non-compliance with this rule may lead to action under RRS 69.

21 TRASH DISPOSAL

Boats shall not put trash in the water. Trash may be placed aboard support and Race Committee boats.

22 PRIZES

Prizes will be awarded as detailed in the Notice of Race.

23 DISCLAIMER OF LIABILITY

Competitors participate in the regatta entirely at their own risk. See RRS 4, Decision to Race. The Organizing Authority, not any of its personnel, will not accept any liability for material damage or personal injury or death sustained in conjunction with or prior to, during, or after the regatta.

34 INSURANCE

Each participating boat shall be insured with valid third-party liability insurance with a minimum cover of R1 000 000 per event or the equivalent.

ADDENDUM A

A Windward-Leeward-Triangle Course Start – 1 – 2 – 3 – 1 – 3 – Finish

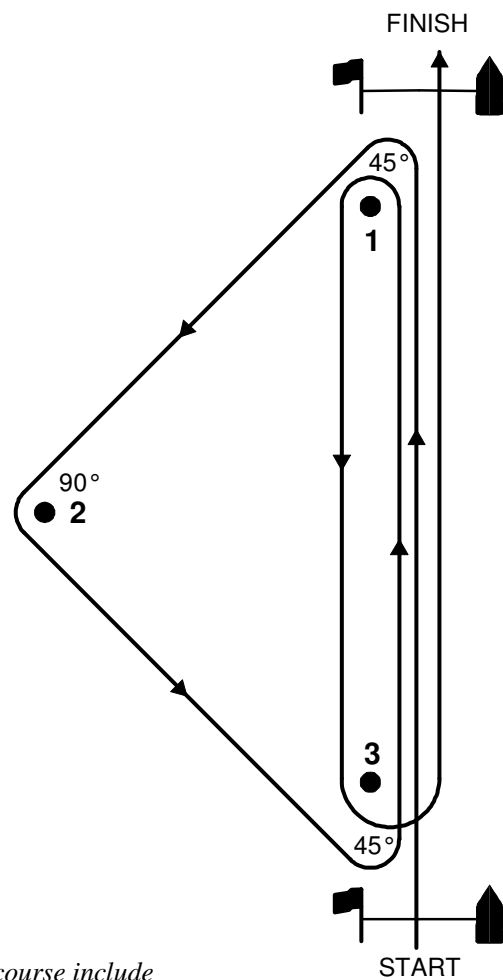

Options for this course include

- (1) increasing or decreasing the number of laps,*
- (2) deleting the last windward leg,*
- (3) varying the interior angles of the triangle (45° – 90° – 45° and 60° – 60° – 60° are common),*
- (4) using a gate instead of a leeward mark for downwind legs (but not reaches),*
- (5) using an offset mark at the beginning of downwind legs (but not reaches), and*
- (6) using the leeward and windward marks as starting and finishing marks.*

Be sure to specify the interior angle at each mark.